

MONTAGEANLEITUNG / SERVICEKARTE - INSTRUKCJA MONTAŻU / KARTA SERWISOWA

Sehr geehrter Kunde, sollte ein Teil fehlen oder beschädigt sein, kreuzen Sie bittedieses deutlich auf der SERVICEKARD an und schicken Sie uns die SERVICEKARD zurück.

Szanowny kliencie, gdyby brakowało jakiejś części lub byłaby uszkodzona, proszę to oznaczyć krzyżykiem na KARCIE SERWISOWEJ i przesać razem z reklamacją.

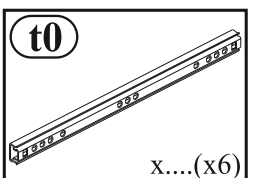
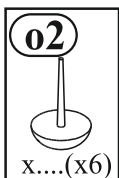
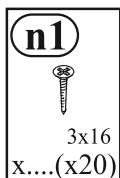
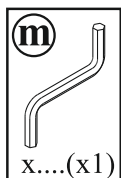
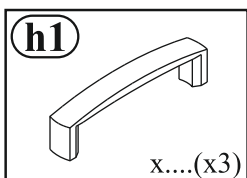
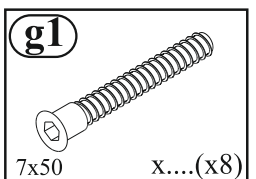
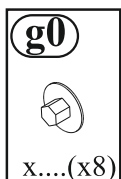
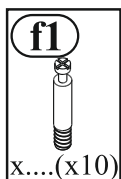
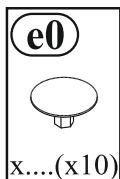
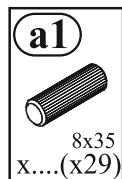
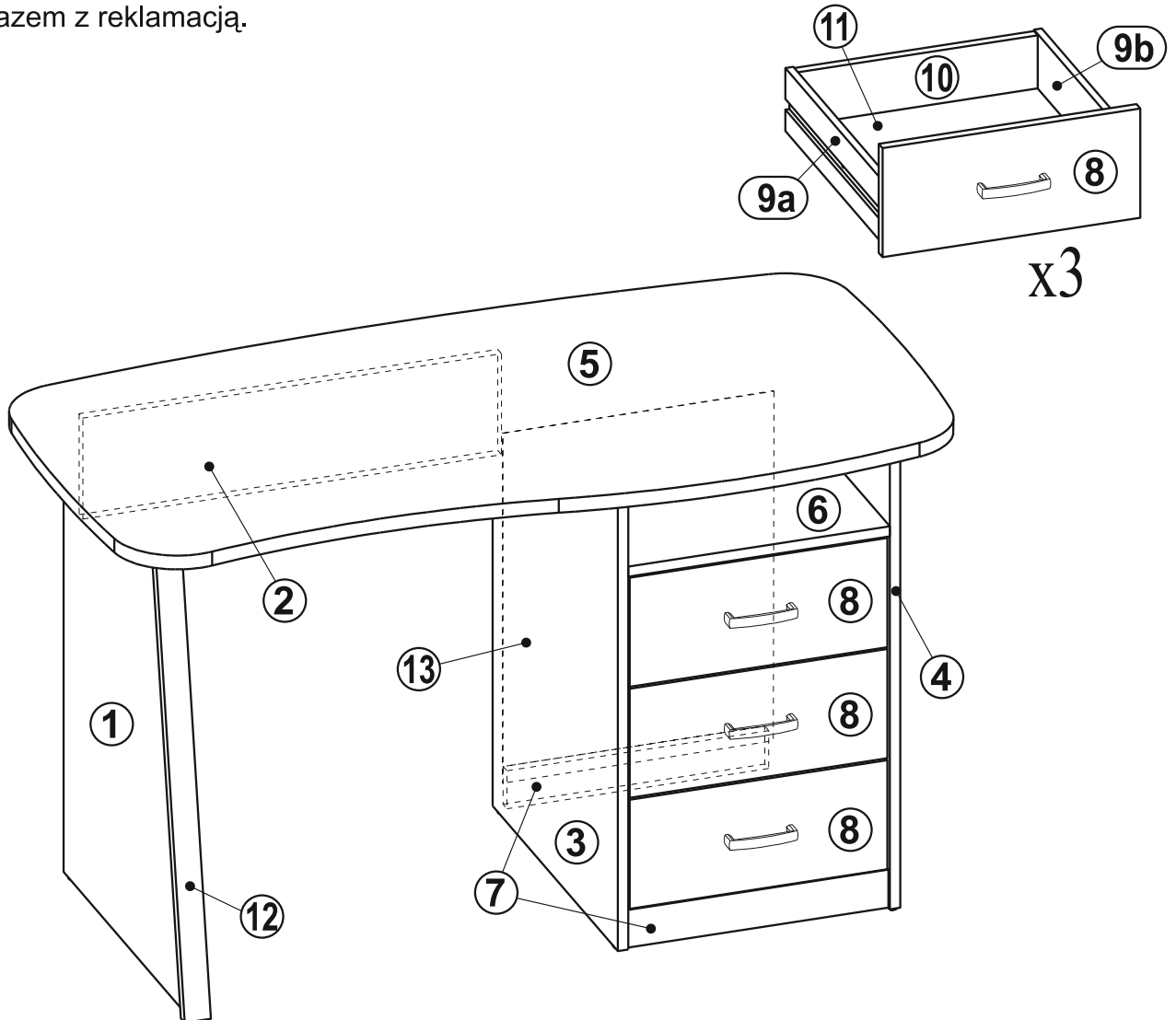

1

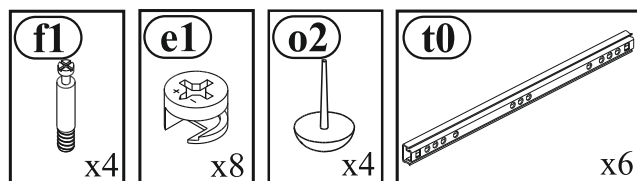
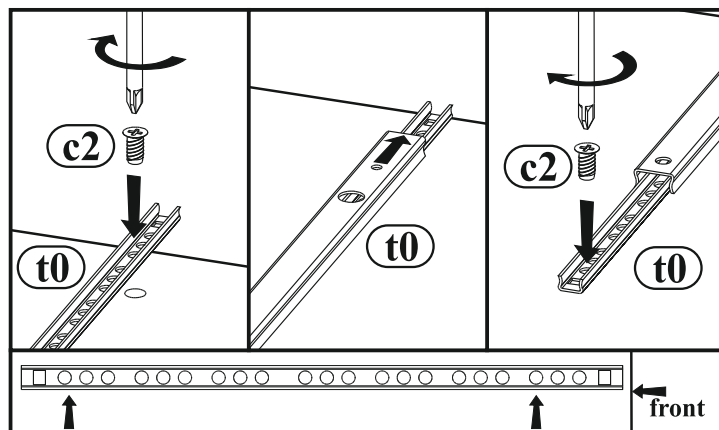
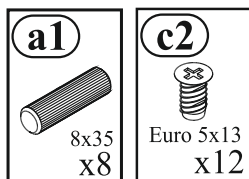
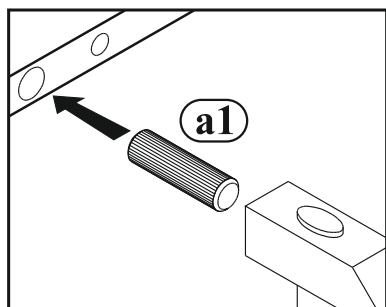
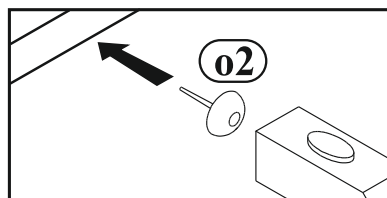
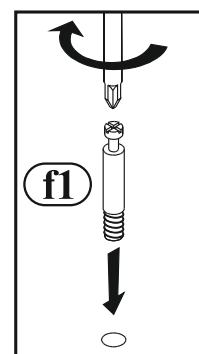
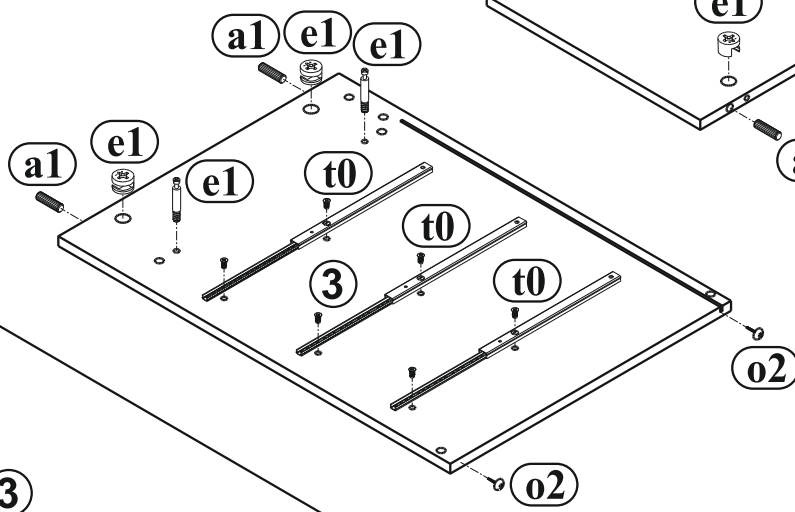
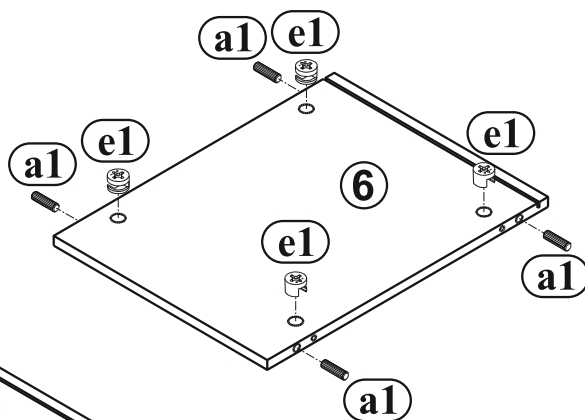
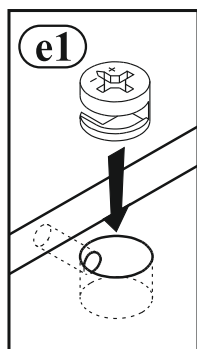
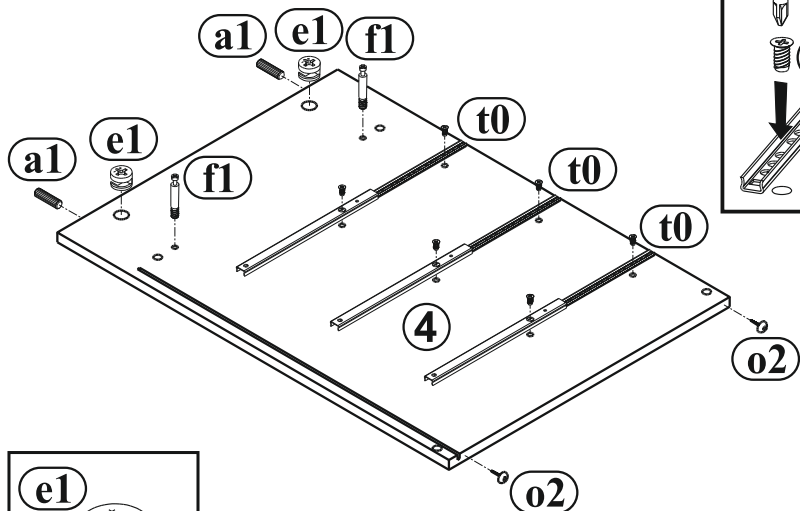
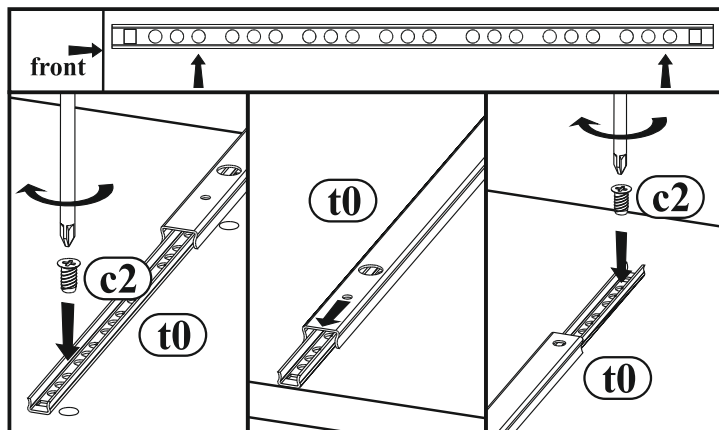

2

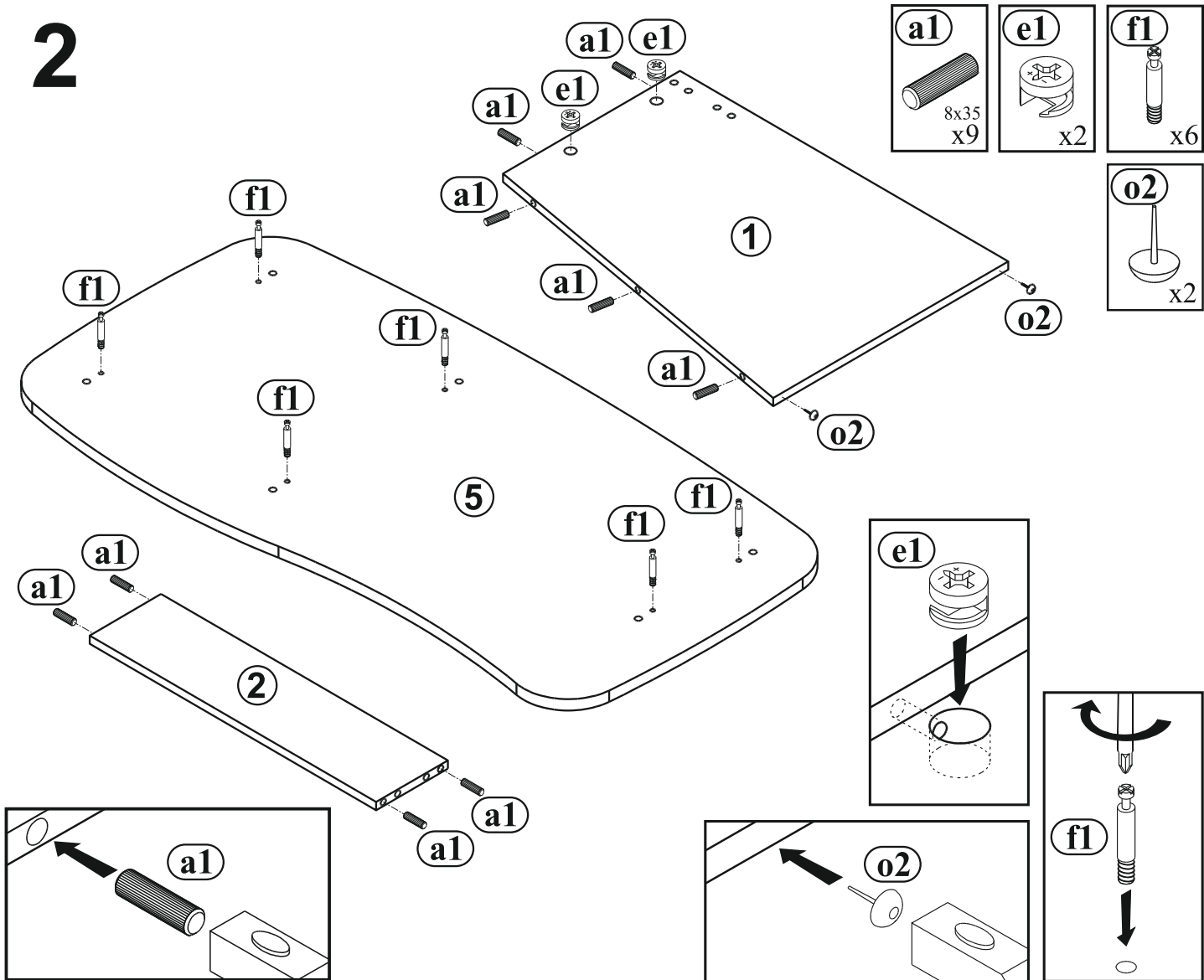

3

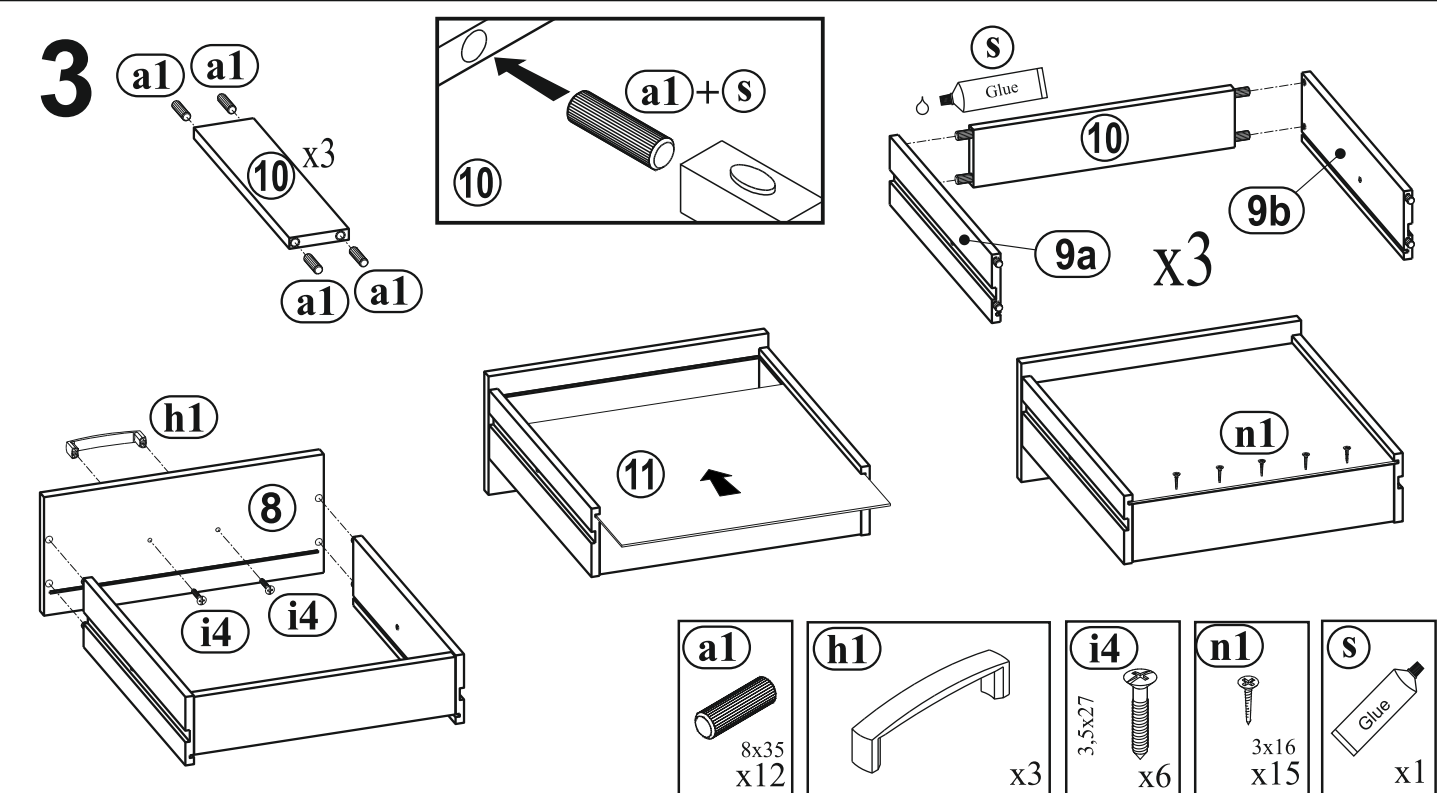

4

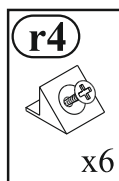
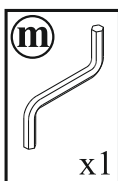
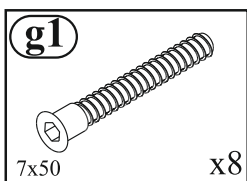
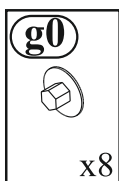
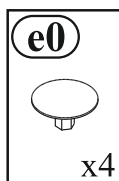
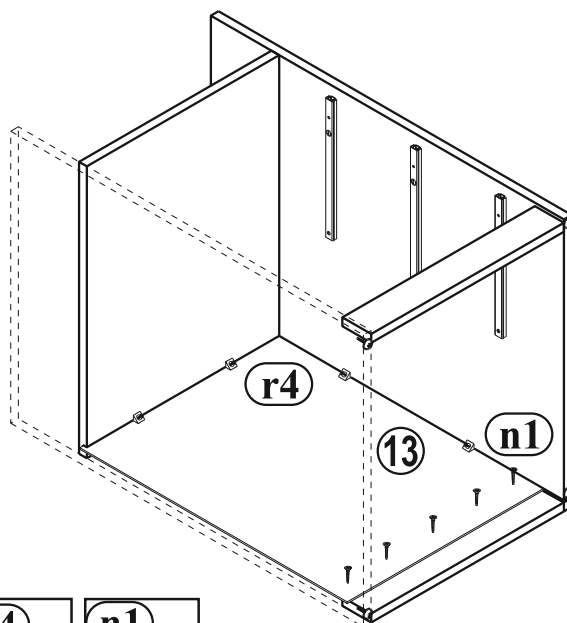
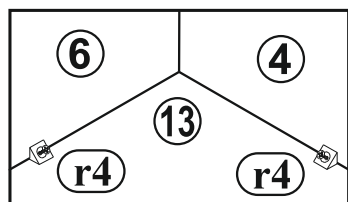
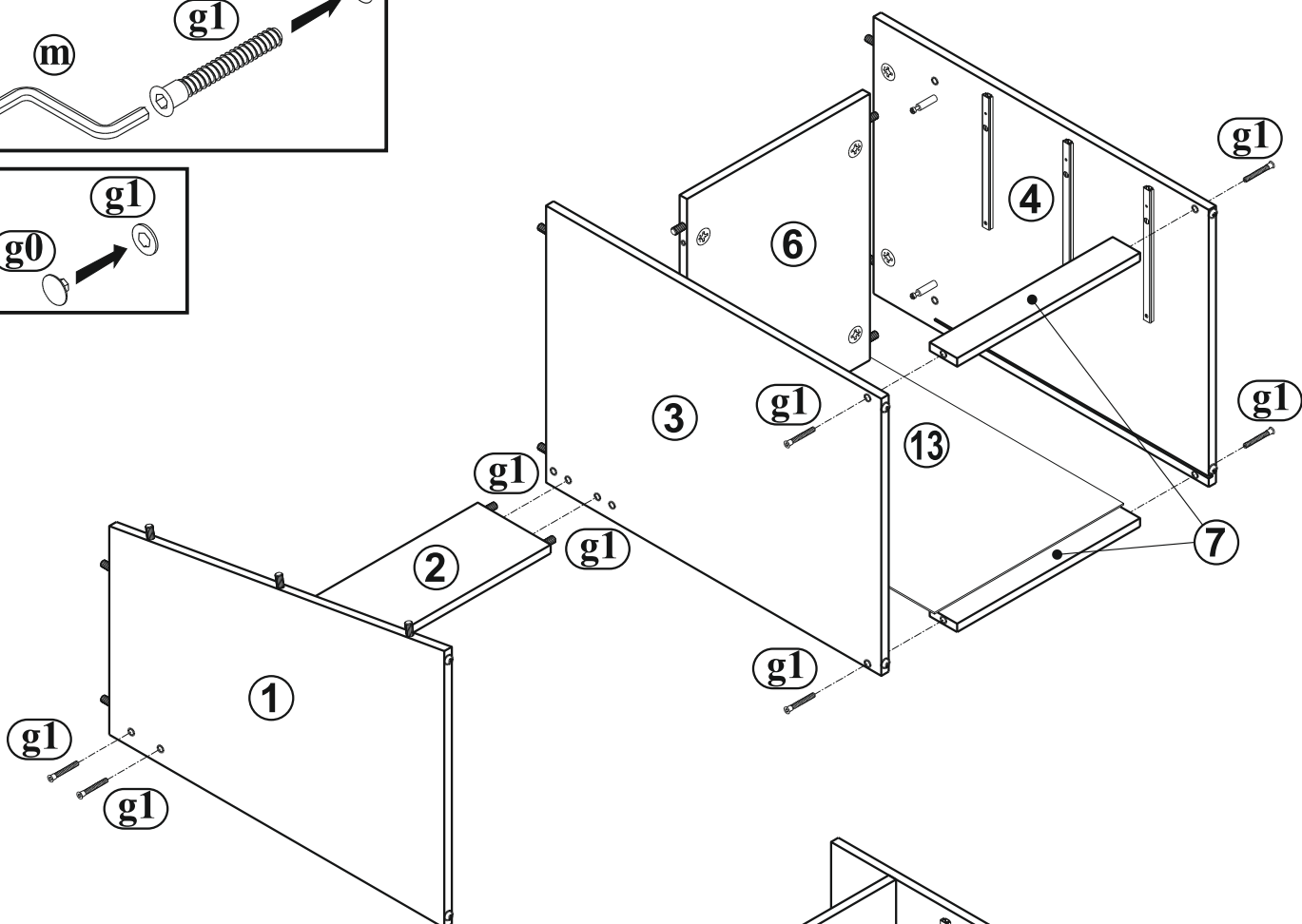
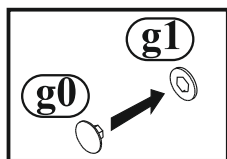
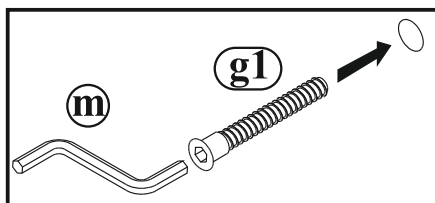
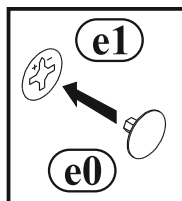
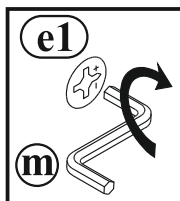
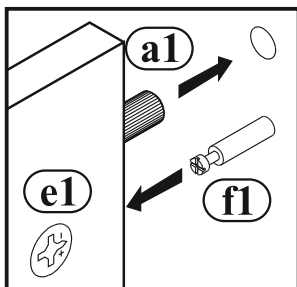

5

